

Products for Lighting

Sep., 2010

LCW100Z1

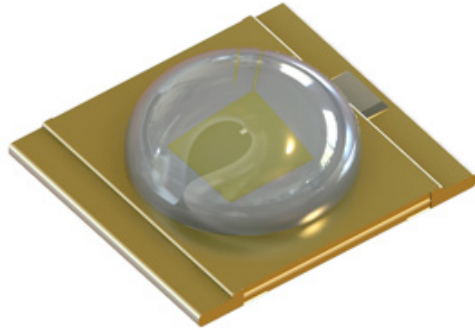

- . Size (mm) : 3.5 x 2.8 x 1.6
- . Luminous efficacy
- **105 ~ 120 lm/W**

Advantages & Benefits :

- . **Tiny size** enables more various and elaborate lighting designs.
- . **High performance in high current input**
 - 6.6~7.8lm @ 20mA (105 lm~120 lm/W)
 - ~ 14.3 lm @ 40mA (~ 113.5 lm/W)
- . Available for **high current** and strong in **thermal resistance** due to Metal Substrate

Applications

- . Indoor general lighting
- . Channel lighting
- . Small lamp
- . Fluorescent lamp replacement
- . Task lamp
- . Line lamp

Electrical Optical Characteristics

Part No.	Color Temp.	Luminous Efficacy	Ø v	CRI	Viewing Angle	V _F	I _F	Thermal Resistance	Absolute Thermal Maximum Ratings
	[K]	[lm/W]	[lm]		[°]	[V]	[mA]	[R _{θJ-c} , °C /W]	[T _J , °C]
LCW100Z1	6300	104.8	6.6	68	120	3.15	20	33	125
	3000	74.6	4.7	80					

LCW100Z2

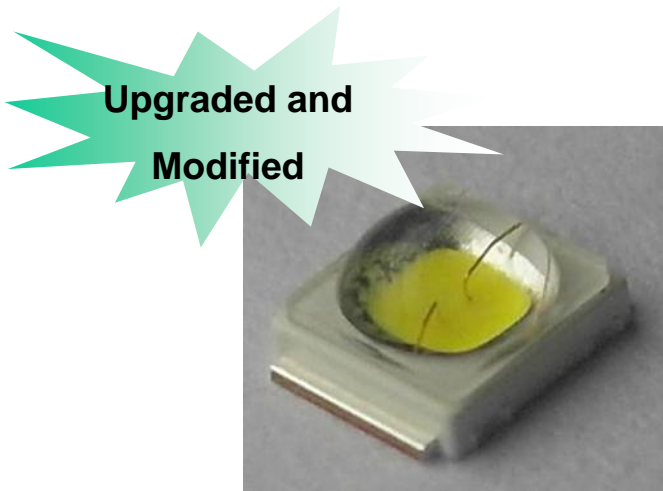

Advantages & Benefits :

- . **Tiny size** enables more various and elaborate lighting designs.
- . **High performance in high current and cost efficiency**
15lm @ 50mA (105 lm/W)
- . Available for **high current (max 150mA)**
- . Low **Thermal resistance** due to Metal Substrate

Applications

- . Size (mm) : 3.5 x 2.8 x 1.69
- . Luminous efficacy
- **105 ~ 120 lm/W**
- . Indoor general lighting
- . Channel lighting
- . Small lamp
- . Fluorescent lamp replacement
- . Task lamp
- . Line lamp

Electrical Optical Characteristics

Part No.	Color Temp.	Luminous Efficacy	∅ v	CRI	Viewing Angle	V _F	I _F	Thermal Resistance	Absolute Thermal Maximum Ratings
	[K]	[lm/W]	[lm]		[°]	[V]	[mA]	[R _{θJ-c} , °C /W]	[T _J , °C]
LCW100Z2	6300	105	16	68	120	3.15	50	50	125
	3000	75	13	80					

KWT/C8WT/C9WT803 (803 Series)



Size : 3 * 2 * 1.2 (0.8) mm

Advantages & Benefits

- . Compact Package
- . High CRI (CRI 80, CRI 90)
- . High Luminous Efficacy
- . Long Life Time(LM80 Clear)

Applications

- . Indoor lighting
- . Flat lighting
- MR16, Par Series
- . Fluorescent lamp
- Bulb type
- . Down lighting

Electrical Optical Characteristics

Part No.	Luminous Intensity		∅ v	Forward Voltage	Luminous Efficacy	CRI	IF	Thermal Resistance	Absolute Thermal Maximum Ratings
	[mcd]	[lm]							
KWT803S	2200		6.9	3.2	108	68	20	76	125°C
C8WT803	Cool	2000	6.3		98.4	80			
	warm	1800	5.7		89				
C9WT803	Cool	1600	5		78	90			
	warm	1400	4.4		68.7				

STWXT36B (728 series)



Size : 5 * 5 * 1.4 mm

Advantages & Benefits

- . High CRI (CRI 80, CRI 90)
- . High Luminous Efficacy
- . Long Life Time (LM80 Clear)
- . Multi Chip Package (3 Chip)
- . 6 Leads structure (Independent operating)

Applications

- . Indoor lighting
 - MR16, Par Series
 - Bulb type
- . Flat lighting
- . Down lighting

Electrical Optical Characteristics

Part No.	Luminous Intensity		$\varnothing v$	Forward Voltage	Luminous Efficacy	CRI	IF	Thermal Resistance	Absolute Thermal Maximum Ratings
		[mcd]	[lm]	[V]	[lm/W]		[mA]	[R θ J-c , °C /W]	[Tj, °C]
STW8T36B	Cool	6300	20	3.2	104	80	60	18	125 °C
STW9T36B	Cool	5700	18	3.2	93.7	90			

→ Lumen of Warm white is around 90% of Cool white

SWT8Q2PA/SWT0Q2PA (5630 Series)



Size : 5.6 * 3.0 * 0.7 mm

Advantages & Benefits

- . 0.3~0.5W Multi Chip Package (2 Chip)
- . Best cost performance
- . 4 Leads structure (Common Anode)
- . Energy Star Bin system(SWT8Q2PA)
- . Long Lifetime (LM80 Clear)

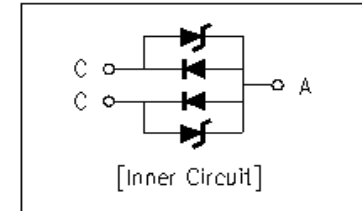

Applications

- . Back Lighting Unit
- . Indoor lighting
 - MR16, Par Series
 - Bulb type
- . Flat lighting
- . Down lighting

Electrical Optical Characteristics

Part No.	Luminous Intensity	$\varnothing v$	Forward Voltage	Luminous Efficacy	CRI	IF	Thermal Resistance	Absolute Thermal Maximum Ratings
	[cd]	[lm]	[V]	[lm/W]		[mA]	[R θ_{J-c} , °C /W]	[T $_J$, °C]
SWT8Q2PA	8.8	27	3.1	87.1	80	100	18	125°C
SWT0Q2PA	10	31		100	65			

SWT0Q14A(5630 Series)

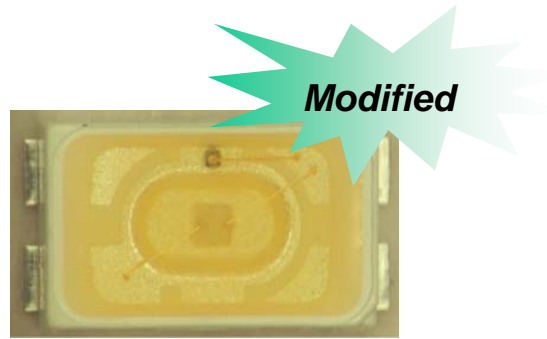

Size : 5.6 * 3.0 * 0.7 mm

Advantages & Benefits

- . 0.2W One Chip Package (1 Chip)
- . World Best cost performance
- . 4 Leads structure (Common Anode)
- . Only 8300K ~ 10000K for Chennel Letter

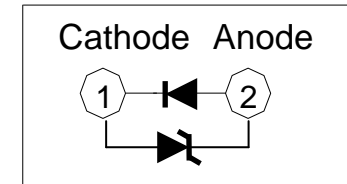

Applications

- . Chennel Letter

Electrical Optical Characteristics

Part No.	Luminous Intensity	$\varnothing v$	Forward Voltage	Luminous Efficacy	CRI	IF	Thermal Resistance	Absolute Thermal Maximum Ratings
	[cd]	[lm]	[V]	[lm/W]		[mA]	[R θ J-c, °C /W]	[T _J , °C]
SWT0Q14A	5.2	15	3.15	75	70	60	22	125°C

Schedule for Mass production

Initial Sample	Reliability sample	Mass production
End of Sep.	End of Sep.	Begin of Oct.

3528 Series



Size : 3.5 * 2.8 * 0.7 mm

Advantages & Benefits

- . 0.3~0.5W Multi Chip Package (2 Chip)
- . Special Color (Pink,Red,White)
- . 4 Leads structure (Common Anode)

Applications

- . Interior Lighting
- . Specail lighting
 - Decoration
 - Entertainment

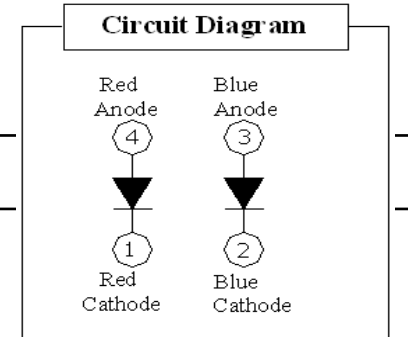

Electrical Optical Characteristics

Part No.	IV			VF	View Angle	Absolute Thermal Maximum Ratings
	White	Red	Pink	[V]	[°]	[Tj, °C]
STWR24A	1,600 (20mA)	280 (20mA)	1,500 (B:14mA, R:11mA)	Blue: 3.2 Red: 2.1	120	125 °C

P4 Series



Size : 8 Pi * 5.08 mm

Advantages & Benefits

- . Various secondary optics available
- . Maximum forward current; **220lm @ 800mA**
- . Available colors : Red, Blue, Green
- . Reflow solderable
- . Warm and Natural White P4 with high CRI for high demand (Ex. Hotel, Display window...) : Clear LM80

Applications

- . Indoor lighting
 - MR16, Par Series
 - Bulb type
- . Outdoor lighting
 - Torch

Electrical Optical Characteristics

Part No.	Color Temp.	Ø v	Luminous Efficacy	CRI	Viewing Angle	V _F	I _F	Thermal Resistance	Absolute Thermal Maximum Ratings
	[K]	[lm]	[lm/W]		[°]	[V]	[mA]	[R _{θJ-c} , °C /W]	[T _J , °C]
W42180	6300	U-rank : 110	96.7	73	127	3.25	350	8.5	145°C
S42180H	4000	93	81.8	80	124				
N42180H	3000	85	74.7	80	124				

P4 (Photosynthetic application)

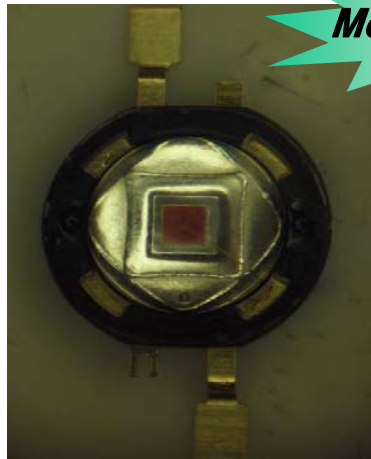

Modified

Size : 8 Pi * 5.08 mm

Advantages & Benefits

- . Special Lighting for Agricultural
- . Reflow solderable
- . Photosynthetic (640 ~690) → 660nm Peak
- . Promote leaves growth (420 ~ 470nm) → 450nm Peak

Applications

- . For Agricultural
- (Down light, Strip Bar, Module)

Electrical Optical Characteristics

Part No.	Peak Wavelength	Radiant Power Ø v	Viewing Angle	V _F	I _F	Thermal Resistance	Absolute Thermal Maximum Ratings
	[nm]	[mW]		[V]	[mA]	[R _{θJ-c} , °C /W]	[T _J , °C]
P42180	660	200	130	2.4	350	9	125°C
D42180	457	468	130	3.25		8.5	

Z5

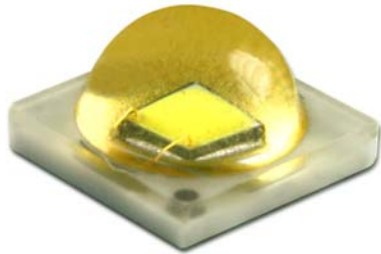

Size : 3.5 x 3.5 x 2.0 mm
MP: May, 2010

Advantages & Benefits

. Compact Size Power Package (3.5x3.5x2.0)

- High brightness and efficiency
- Cost competitive
- Life time (40khr@Junction temp=100°C) Clear LM80

Schedule for WW,R,G,B,A Mass production

Part No	Reliability sample	Mass production
NW CRI80	Aug	Sept
WW, NW CRI90	Aug	Sept

Electrical Optical Characteristics

Part No.	CCT / DW [K] / [nm]	Ø v [lm]	Luminous Efficacy [lm/W]	CRI	Viewing Angle [°]	VF [V]	IF [mA]	Thermal Resistance [RθJ-c, °C /W]	Absolute Thermal Maximum Ratings [TJ, °C]
SZW05A0A	6300	110	95	70	120	3.3	350	11	145°C
SZWW5A0A	3000	75	65	80	120	3.3	350	11	145°C
SZB05A0A	460	18	15	-	128	3.5	350	11	145°C
SZG05A0A	525	70	57	-	128	3.5	350	11	145°C
SZA05A0A	590	42	48	-	123	2.5	350	11	125°C
SZR05A0A	625	50	57	-	123	2.5	350	11	125°C

Z6

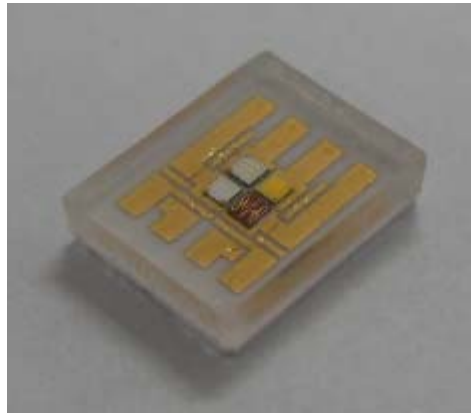

Size : 7 x 9 x 1.5 mm

MP : Oct., 2010

Advantages & Benefits

. New full color LED (R,G,B, Neutral white)

- High brightness and efficiency
- Compact
- 8 Leads structure (Independent operating)
- Various color expression
- Expected Life time (40khr@Junction temperature)

Applications

- | | |
|--------------------------|--------------------------|
| . Indoor lighting | . Outdoor lighting |
| - Decorative lighting | - Architectural lighting |
| - Entertainment lighting | - Mood lighting |

Electrical Optical Characteristics

Part No.	Ø v [lm/W]				IF	Thermal Resistance	Absolute Thermal Maximum Ratings
	Blue	Green	Red	N- White	[mA]	[RθJ-c , °C /W]	[Tj, °C]
Z6	15	65	35	65	350	4	125 °C

Schedule for Warm & Neutral White Mass production

Initial Sample	Reliability sample	Mass production
Aug	End. Of Sep	Oct

Z7

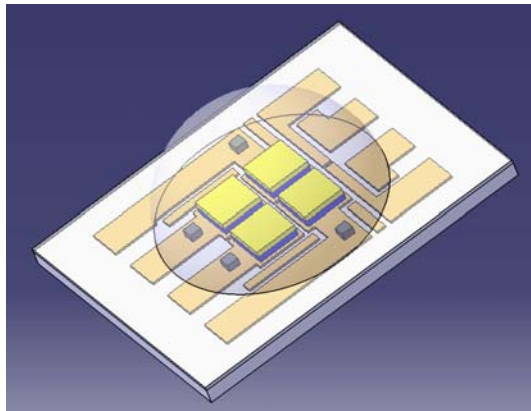

Size : 7 x 9 x 3.4 mm
Mass product : Oct 2010

Advantages & Benefits

. High brightness and efficiency

- Compact
- 8 Leads structure (Independent operating)
- Various second optic available
- Expected Life time (40khr@Junction temp=)

Applications

- | | |
|--------------------|--------------------|
| . Indoor lighting | . Outdoor lighting |
| - Bulb replacement | - Street lamp |
| - Down light | - Tunnel lamp |

Electrical Optical Characteristics

Part No.	Color Temp.	Ø v	Luminous Efficacy	CRI	Viewing Angle	VF	IF	Power	Absolute Thermal Maximum Ratings
	[K]	[lm]	[lm/W]		[°]	[V]	[mA]	[W]	[Tj, °C]
Z7 Cool	6300	800	82	70	127	3.5	700/chip	9.8	145°C
Z7 Warm	3000	600	61.2	80	124	3.5	700/chip	9.8	145°C

Schedule for Mass production

Initial Sample	Reliability sample	Mass production
End of Aug	End of Oct	Nov

A3



Size : 12 pi X 6.54 mm

Under the Mass Production

Advantages & Benefits

- . **AC driven** without converter or driver
 - Simplify circuit design
 - No conversion loss
 - Cost down
 - Reduce weight
 - No lifespan reduction by secondary components
- . Dimming available

Applications

- . Indoor lighting
- . Outdoor lighting
- . Bulb replacement
- . Down Light

Electrical Optical Characteristics

Part No.	V _F [V]	I _F [mA]	∅ _v [lm]	Color Temp. [K]	CRI	Viewing Angle [°]	Absolute Thermal Maximum Ratings [T _J , °C]	Thermal Resistance [R _{θJ-c} , °C /W]
AN3200	100, 110	40	180	3000	80	130	125	6
AN3220	220, 230	20						
AW3200	100, 110	40	260	6300	75			
AW3220	220, 230	20						

A4



Size : 7 x 7 x 2.95

Under the Mass Production

Advantages & Benefits

- . **AC driven** without converter or driver
 - High voltage operation (AC50~55V)
 - High efficiency Acriche
 - ESD protection (>4KV,HBM)
 - Life time (40khr@Junction temp=85℃)
- Reduce weight

Applications

- . Indoor lighting
- . Bulb replacement
- . Down Light
- . Ceiling panel light
- . Outdoor lighting

Electrical Optical Characteristics

Part No.	Operating condition	Power dissipation	Øv	Efficiency	Color Temp.	CRI	Viewing Angle	Thermal Resistance
	[mA, RMS@55V]	[W]	[lm]	[lm/W]	[K]		[°]	[RθJ-c, °C /W]
AN4240	20	0.83	60	72	3000	85	134	10
AW4240		0.80	80	100	6300	70		

A5



Size : 7 x 7 x 2.95 mm
MP : June, 2010

Advantages & Benefits

- . **AC driven** without converter or driver
 - High voltage operation (AC110 / 220V)
 - 2W Product
 - Expected life time (40khr@Junction temp=85 °C)

Applications

- . Indoor lighting
- . Outdoor lighting
- . Bulb replacement
- . Candle lamp

Electrical Optical Characteristics

Part No.	Operating condition [mA, RMS]	Power dissipation [W]	Øv [lm]	Efficiency [lm/W]	Color Temp. [K]	CRI	Viewing Angle [°]	Thermal Resistance [RθJ-c, °C /W]
AW52X0	20 @110V, 10@220V	1.67	90	54	6300	70	140	11
AN52X0			70	42	3000	80		

Schedule for A5 Mass production

Initial Sample	Reliability sample	Mass production
-	May	End of June

A8 (Big A)

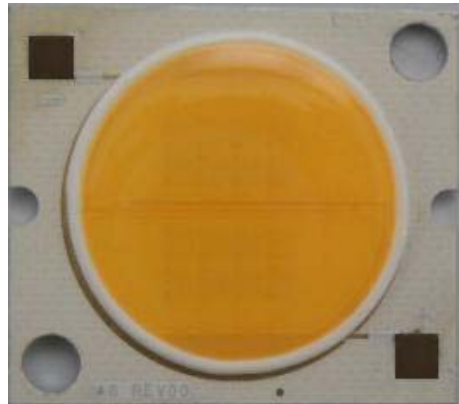

Size : 25 x 25
MP : Dec., 2010

Advantages & Benefits

- . AC driven without converter
- . Reduce system cost
- . Compact design

Applications

- . Downlight
- . Architectural Lighting
- . Industrial Lighting
- . Replacement Lamps
- . PAR, Bulb

Electrical Optical Characteristics

Part No.	Operating condition	Power dissipation	Øv	Efficiency	Color Temp.	CRI	Viewing Angle	Thermal Resistance
	[mA, RMS@220V]	[W]	[lm]	[lm/W]	[K]		[°]	[RθJ-c, °C /W]
A8(Big A)	60	12~15	700 ~ 1000	60	3000	82	120	-

Schedule for Improved A7 Mass production

Initial Sample	Reliability sample	Mass production
Aug.	Oct.	Dec.,2010

New Bin System for lighting product

-Applied to : P3-II, P4, P6, P7, P9, Z1, Z2

-From : 1st of Oct, 2010

Bin system for Lighting product

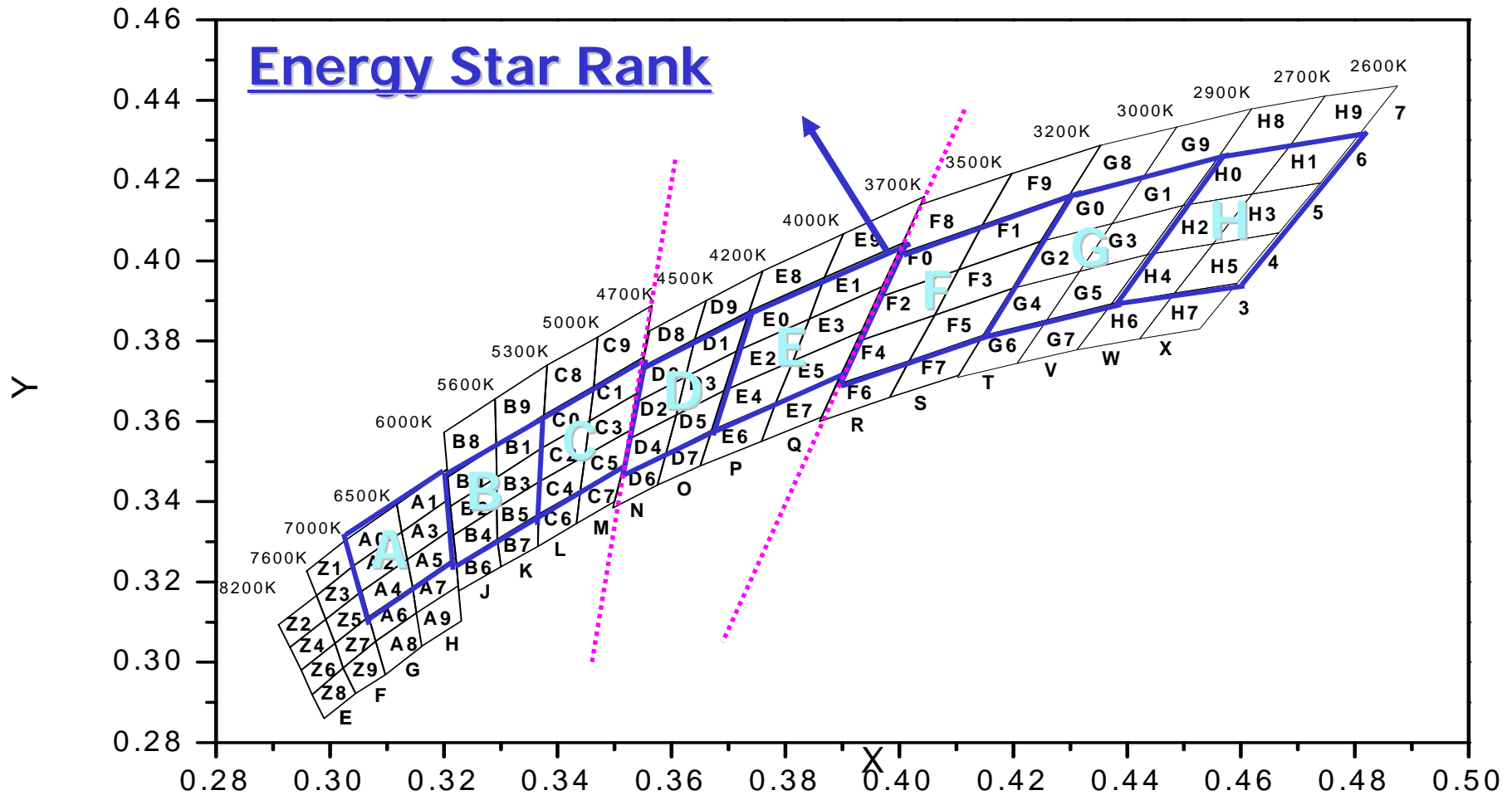

- A ~ H Rank : Energy Star Bin (ANSI BIN)

- Each Rank consists of 6 sub bins

PURE WHITE(13 → 39EA)

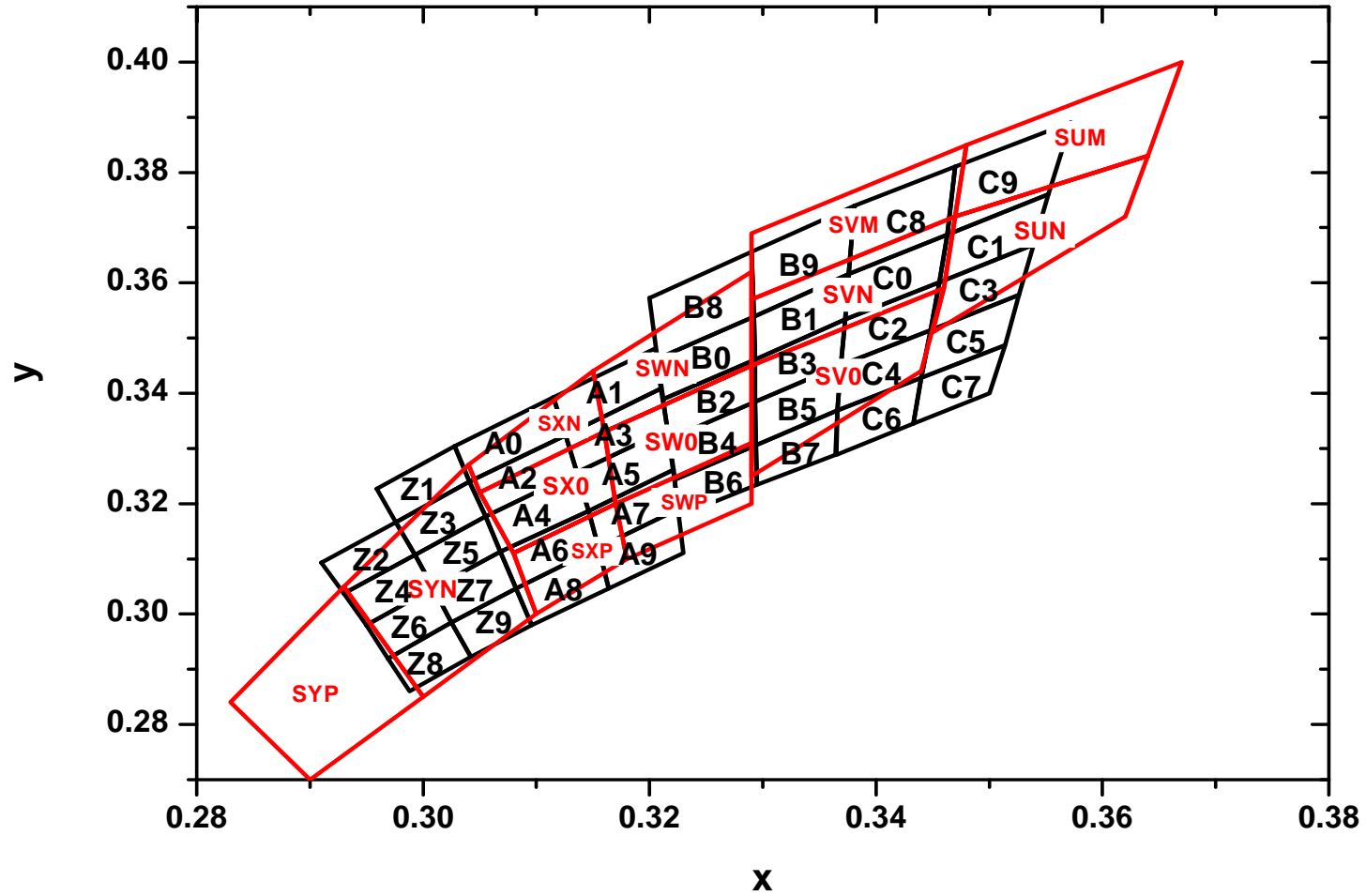

NATURAL WHITE(9 → 20EA)

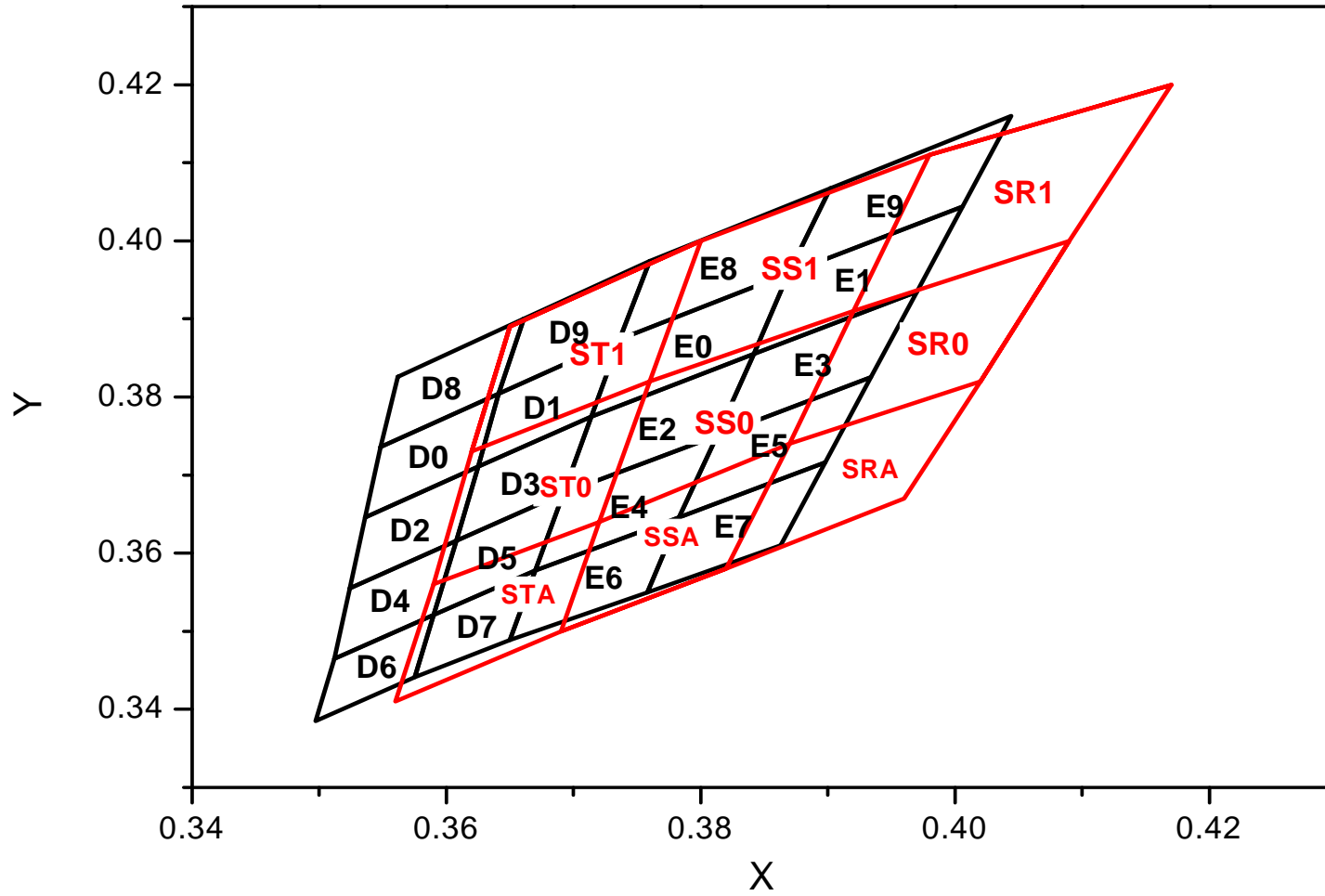

WARM WHITE(16 → 30EA)

