

Application Note

Designing with Acrich 2

Introduction

Acrich2 is designed to connect directly to AC source via 2wires with no AC/DC converter which is essential for conventional general lighting. As there is no need of converter, Acrich2 can realize as close life-time as original LED and make a better use of a space in many applications.

Also, Acrich2's high power factor can show best energy saving effect in many lighting applications.

4W module



8W module



12W module



Features

- Directly connect to AC power using a Acrich IC
- High power efficiency
- High power factor
- Low THD
- Long life time
- The simplest BOM
- Miniaturization
- Lead free product
- RoHS compliant

Applications

- Replacement lamp
- Down light
- Ceiling light
- Industrial Light

Contents

1. Driver Configuration

- 1.1 Description -----
- 1.2 Acrich IC PKG Pin Configurations -----
- 1.3 Absolute Maximum Ratings -----

2. Acrich IC Module Circuit Configurations

- 2.1 Circuit Configurations (8W module) -----
- 2.2 Circuit Configurations (12W module) -----
- 2.3 Functional Description of Acrich IC Module -----
- 2.4 Surge Protection Circuit (Optional) -----
- 2.5 EMI Reduction Circuit (Optional) -----
- 2.6 Dimming Performance -----

3. Electrical protection point

- 3.1 Wire solder pad protection -----
- 3.2 Wire hole in MCPCB protection-----

1. Driver Configurations

1.1 Description

- Acrich IC has a direct-driving architecture that drives Acrich directly from AC supply, without AC-DC conversions.
- Acrich IC has 8 channels, and activations of these channels and their current flows are controlled by its internal controller so that Acrich currents, power dissipation and power factor are regulated within proper ranges.
- Acrich IC integrates all peripheral components including bridge diodes and passive components, providing a simple and effective solution for LED light applications.

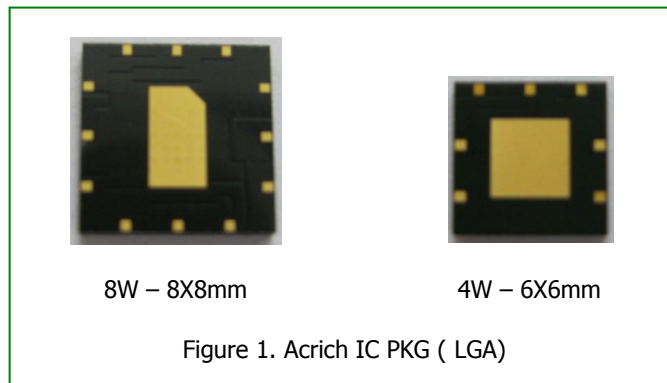

■ Features

- High power efficiency
- Reduce lamp weight
- Flicker improvement
- Low circuit cost
- No lifespan reduction by secondary components

■ Specifications

- AC input range 90~120V(100V)/100~144V(120V)/200V~264V (220V/230V/240V)
- Rated power 4W / 8W
- Power efficiency 90%
- Total harmonic distortion 25% ↓
- Power factor 0.95 ↑
- Life time 87,000hrs ↑

1. Driver Configurations

1.2 Outline of Acrich IC

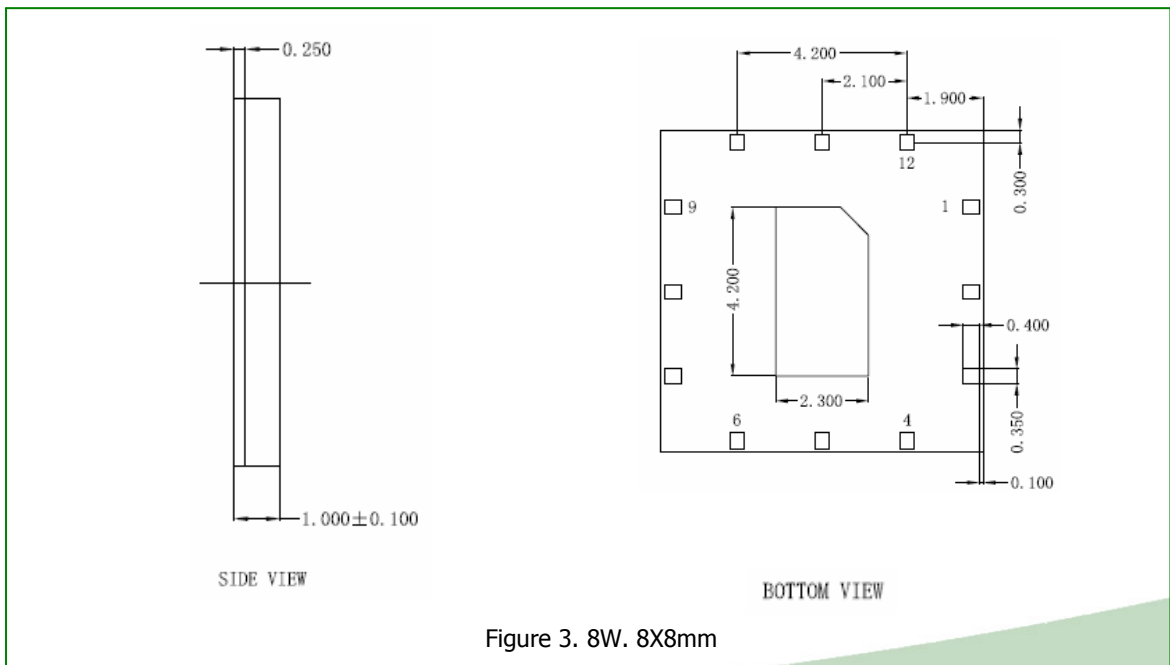
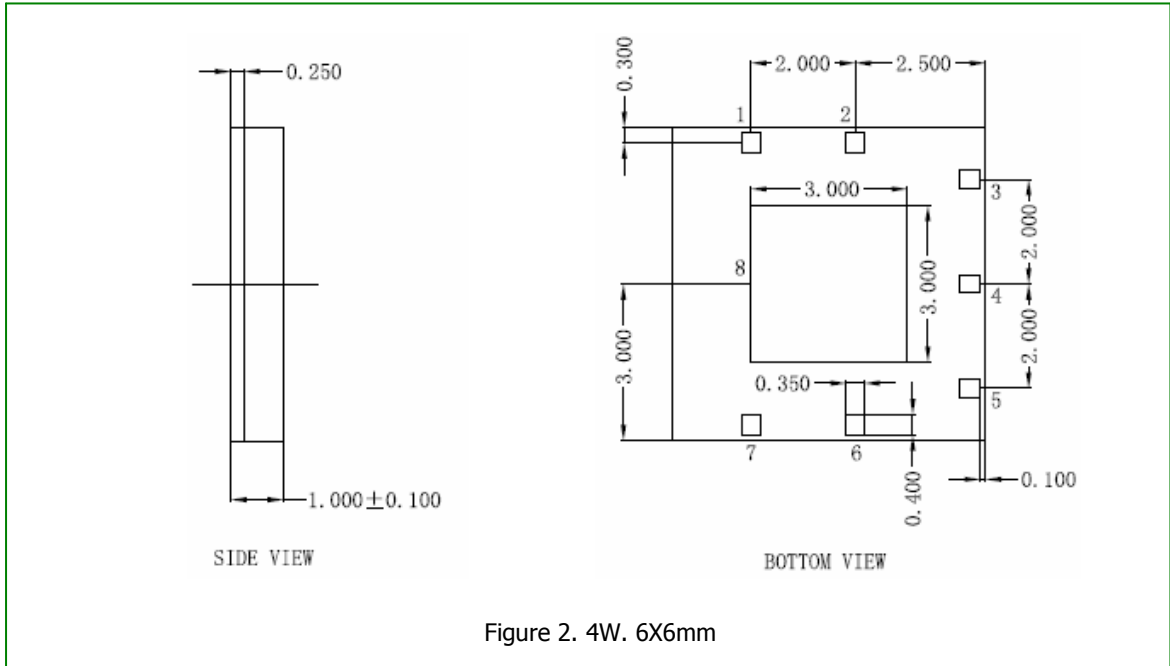

1. Driver Configurations

1.3 Absolute Maximum Ratings (Acrich IC)

Table 1. Absolute Maximum Ratings for Acrich IC

Characteristics	Symbol	Unit	Value
Operating Voltage – 220V	Vopt	Vac	264
Operating Voltage – 230V	Vopt	Vac	264
Operating Voltage – 240V	Vopt	Vac	264
Operating Voltage – 120V	Vopt	Vac	144
Operating Voltage – 100V	Vopt	Vac	120
Junction Temperature	Tj	℃	125
Operating Temperature	Topr	℃	- 30 ~ 100
Storage Temperature	Tstg	℃	- 40 ~ 120

2. Acrich IC Module Circuit Configurations

2.1 Circuit Configurations – 4W Module

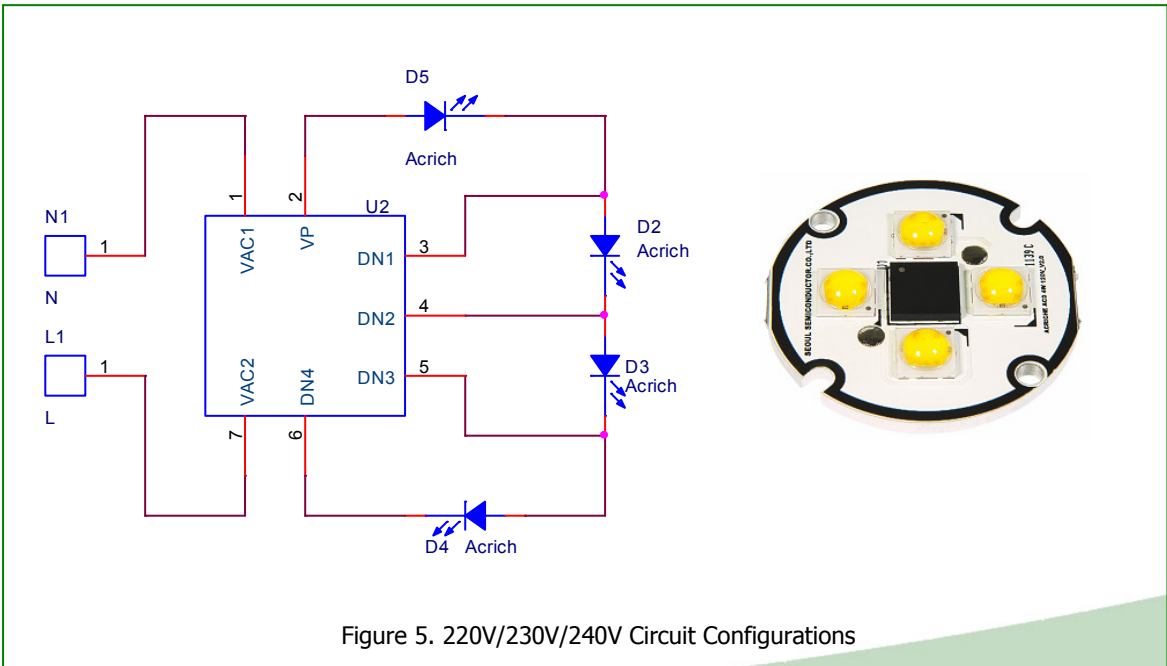
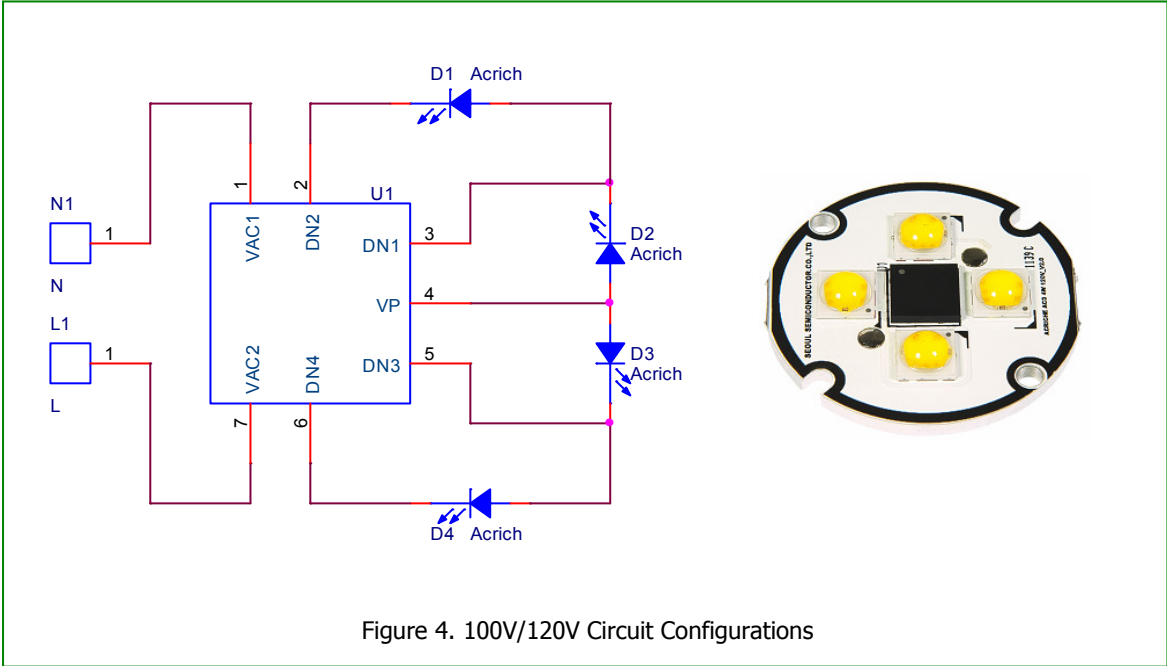

2. Acrich IC Module Circuit Configurations

2.1 Circuit Configurations – 8W Module

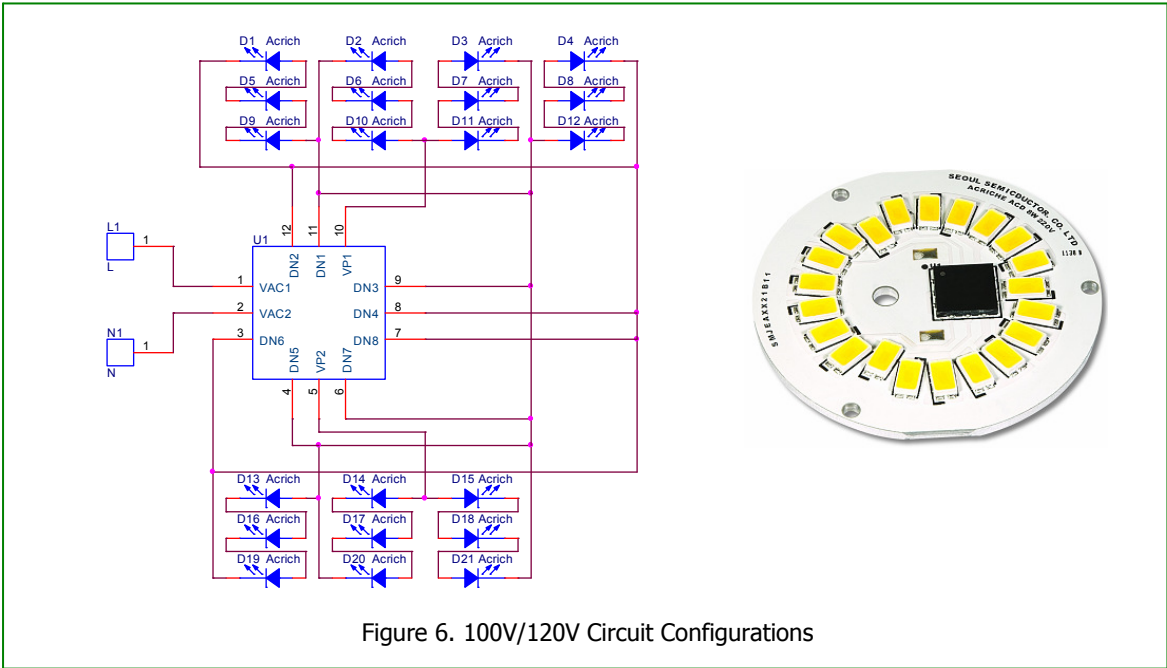

Figure 6. 100V/120V Circuit Configurations

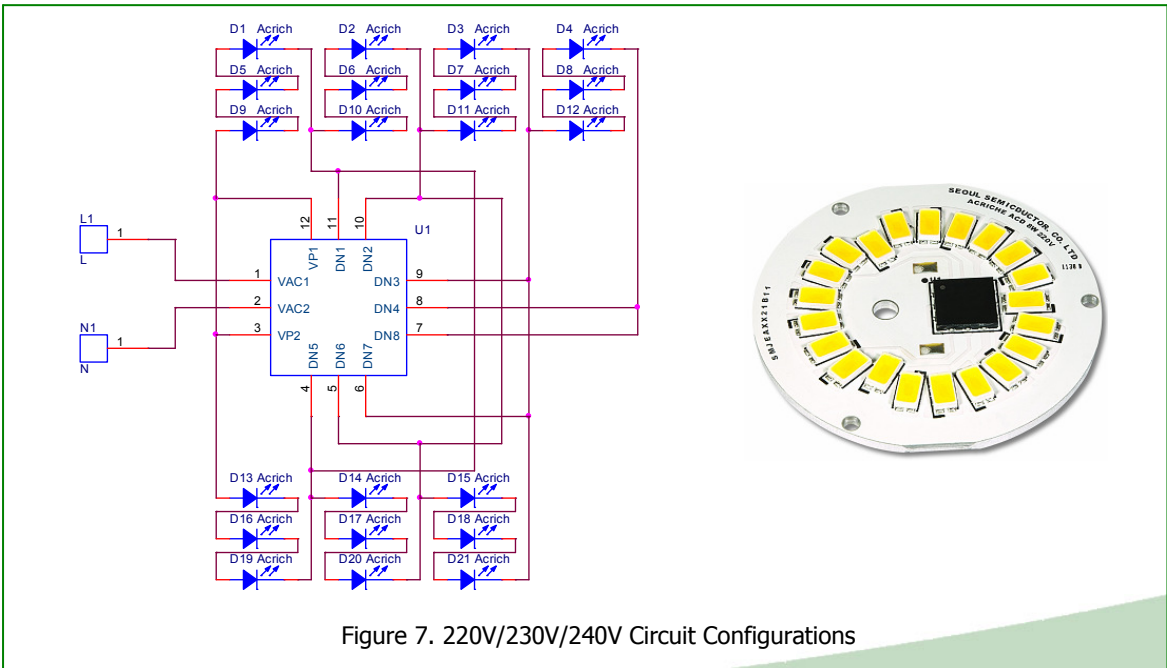

Figure 7. 220V/230V/240V Circuit Configurations

2. Acrich IC Module Circuit Configurations

2.2 Circuit Configurations – 12W Module

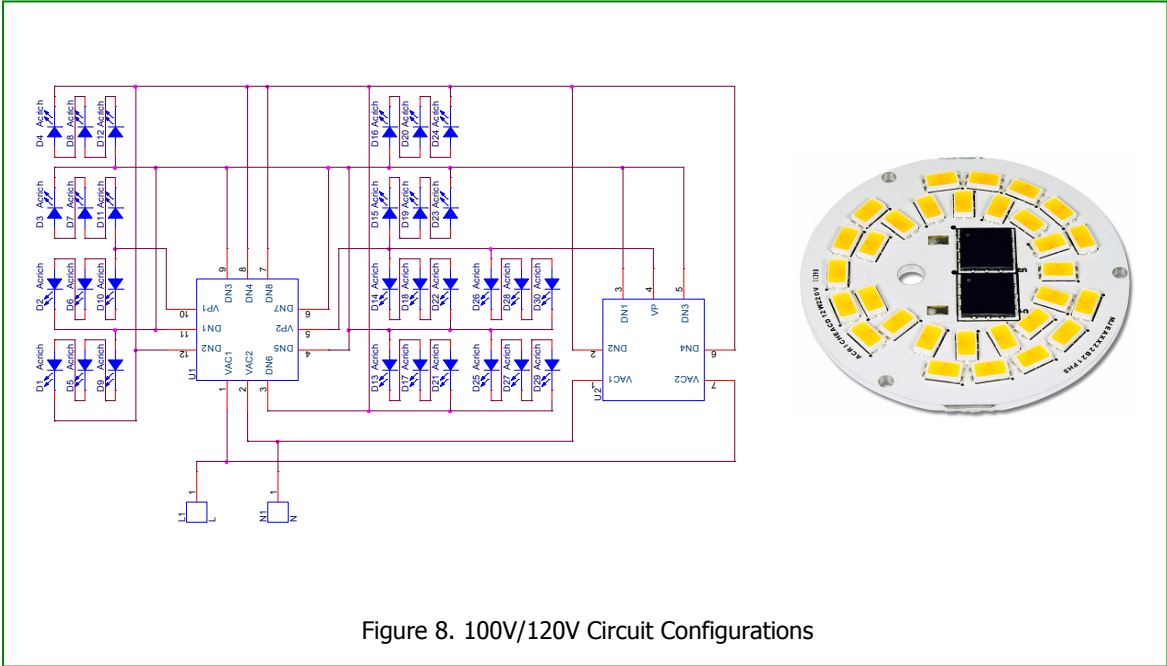

Figure 8. 100V/120V Circuit Configurations

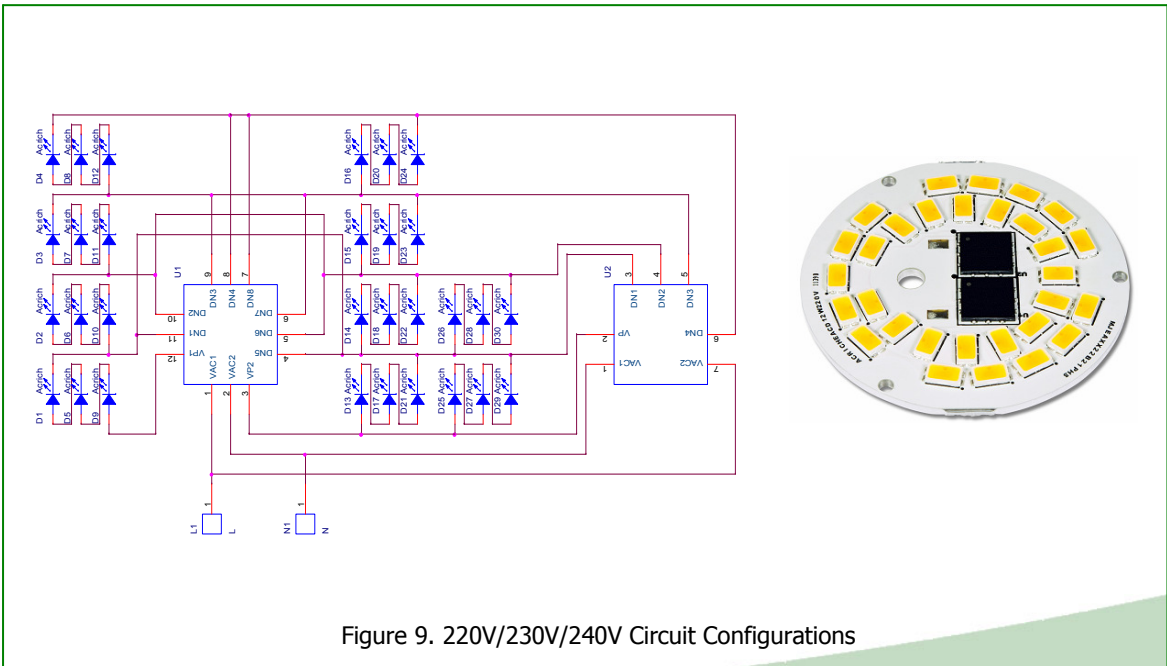

Figure 9. 220V/230V/240V Circuit Configurations

2. Acrich IC Module Circuit Configurations

2.3 Functional Description of Acrich IC Module _ 100V/120V 8W Module

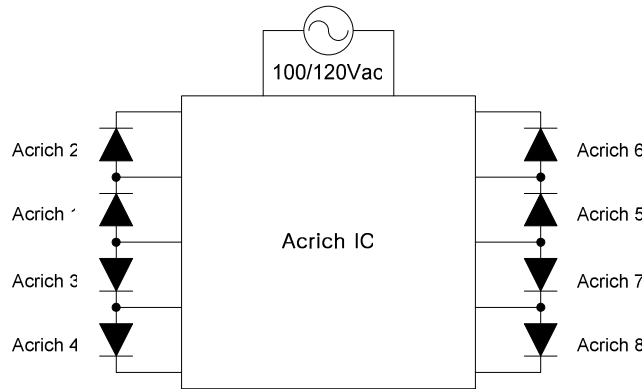

Figure 10. Circuit Diagram

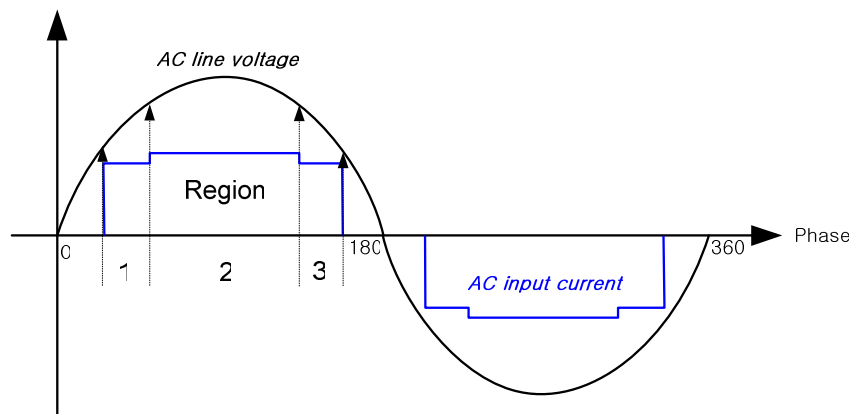

Figure 11. AC Input Voltage Current Waveform

Table 2. Operation of each Acrich (phase 0 ~ 180°)

Region	1	2	3
Acrich 1, 3, 5, 7	ON	ON	ON
Acrich 2, 4, 6, 8	OFF	ON	OFF

2. Acrich IC Module Circuit Configurations

2.3 Functional Description of Acrich IC Module _ 220V/230V/240V 8W Module

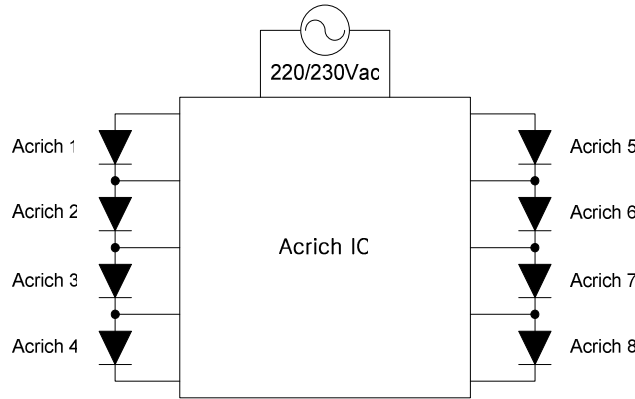

Figure 12. Circuit Diagram

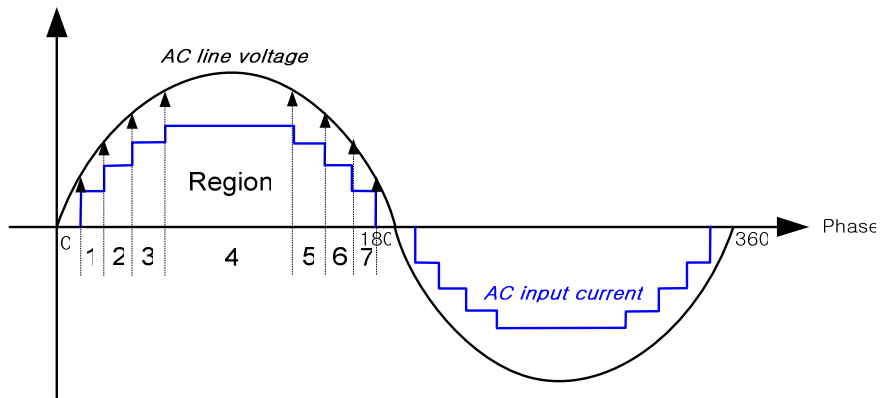

Figure 13. AC Input Voltage_Current Waveform

Table 3. Operation of each Acriche (phase 0 ~ 180°)

Region	1	2	3	4	5	6	7
Acrich 1, 5	ON	ON	ON	ON	ON	ON	ON
Acrich 2, 6	OFF	ON	ON	ON	ON	ON	OFF
Acrich 3, 7	OFF	OFF	ON	ON	ON	OFF	OFF
Acrich 4, 8	OFF	OFF	OFF	ON	OFF	OFF	OFF

2. Acrich IC Module Circuit Configurations

2.4 Surge Protection Circuit

A metal oxide varistor (MOV) is often used to protect lighting systems from electrical surges and ring-wave effects, and help manufacturers meet safety and performance standards. The MOV prevents short-duration voltage impulse. Lightning tests (IEC 61000-4-5) and ring-wave Tests (IEEE C.62.41) can be used for these real-life threat simulation in the lab.

A surge protection circuit (SPC) consists of two components (MOV & fusible resistor) and it is not necessary for normal operation of the Acrich IC module.

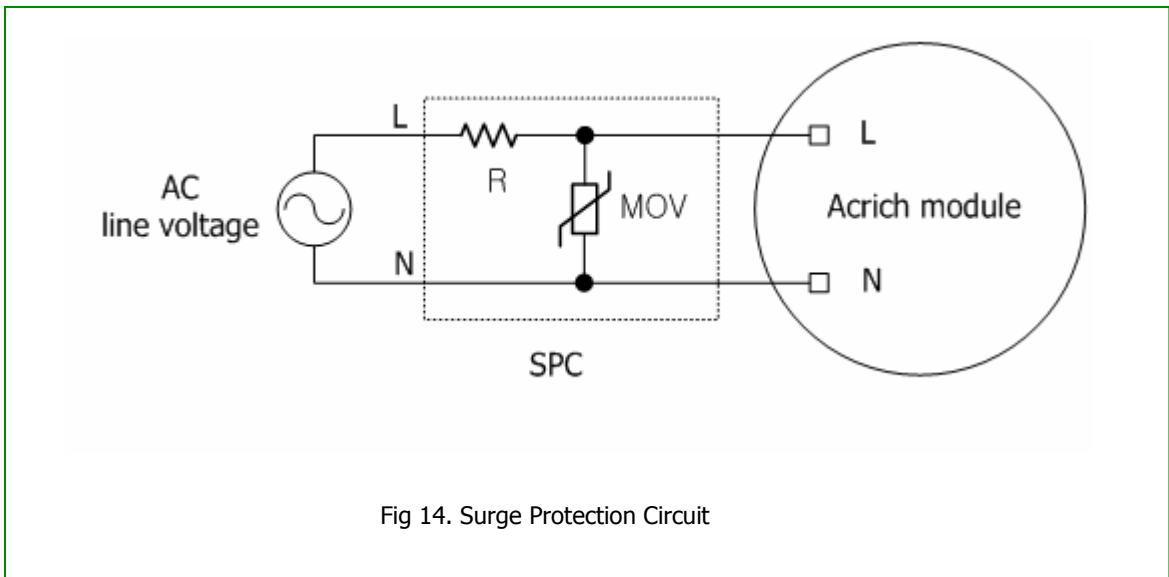

Fig 14. Surge Protection Circuit

Table 4. SPC Components Value

Voltage	Type	R	MOV
100V/120V	4W module	22Ω. 5%. 1W	XXX-391D07 Or XXX-431D07
	8W module		
	12W module		
220V/230V/240V	4W module		
	8W module		
	12W module		

2. Acrich IC Module Circuit Configurations

2.5 EMI Reduction Circuit (optional)

To reduce EMI, a MLCC (Metal Layer Ceramic Capacitor) can be connected in parallel with MOV

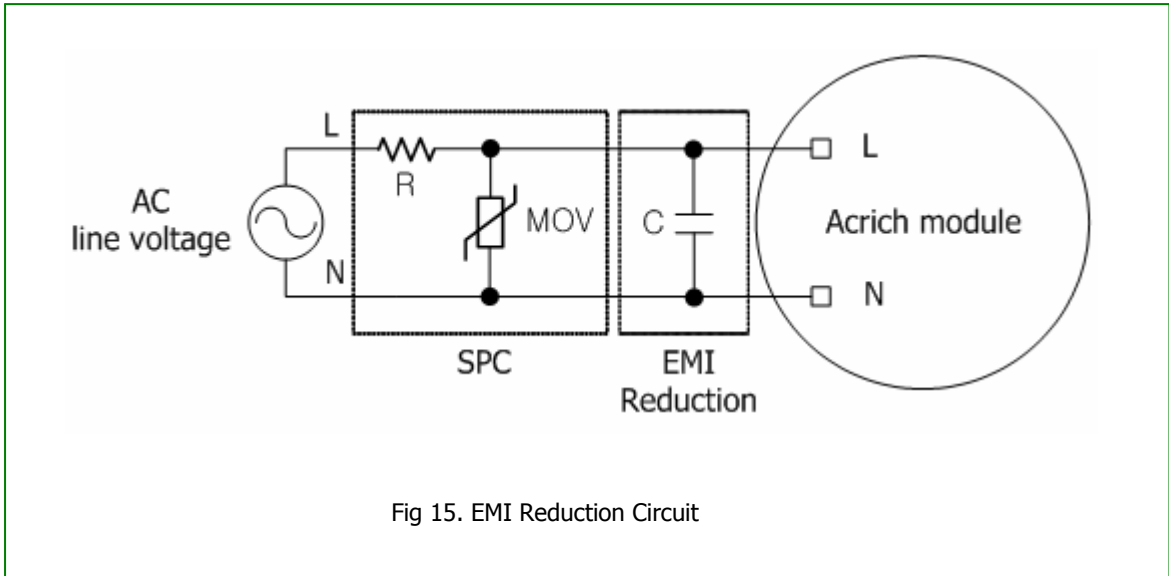

Fig 15. EMI Reduction Circuit

Table 5. Capacitor (C) selection guide

Type	Voltage	Description	Q'ty
8W module	100V/120V	MLCC 10nF 630V X7R 3225 [1]	1
12W module	100V/120V		1
	220V/230V/240V		1

* 4W modules and 8W 220V/230V/230V module meet the EMI standard without capacitor

[1] Capacitor type & capacitance value can be changed by an electrical performance (Power Factor, THD, etc...)

2. Acrich IC Module Circuit Configurations

2.6 Dimming Performance (TRIAC Dimmer)

Incandescent lamp replacement with LED lamps is recently growing by leaps and bounds. One of the requirements for these LED lamps is compatibility with dimmers designed for incandescent lamps. Incandescent lamp primarily utilize phase modulating dimming through TRIAC switches to control the power sent to the bulb.

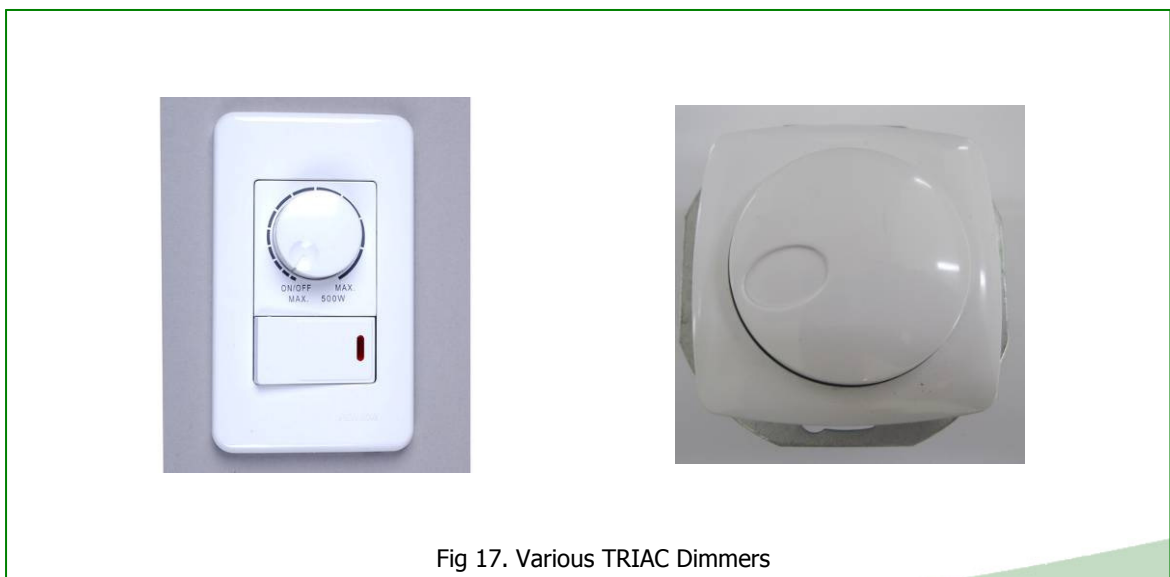
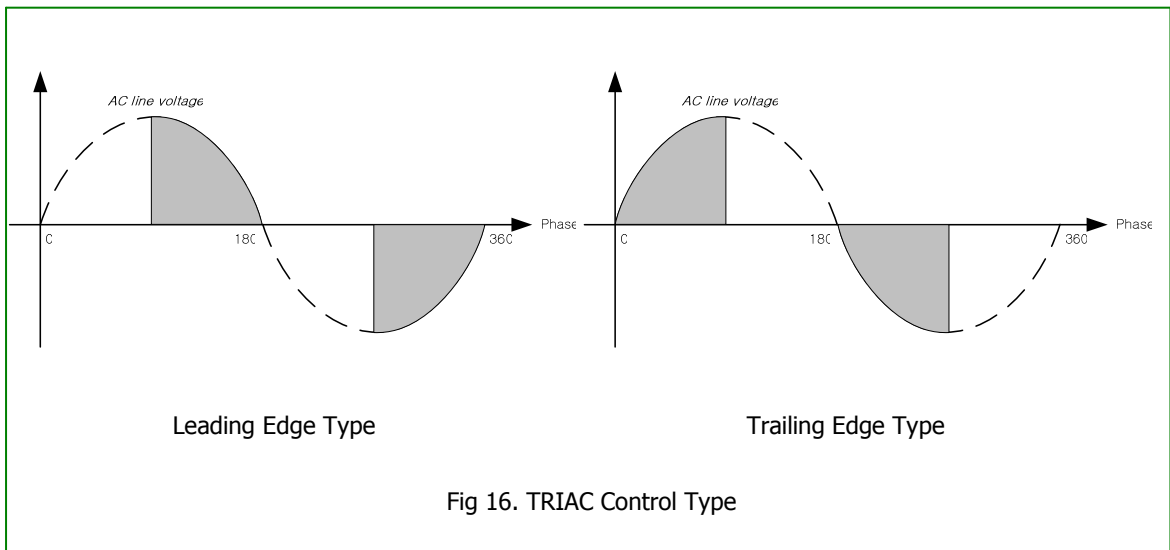

2. Acrich IC Module Circuit Configurations

2.6 Dimming Performance of Acrich IC Module

Acrich IC Module's dimming performance shows different dimming range according to dimmer types

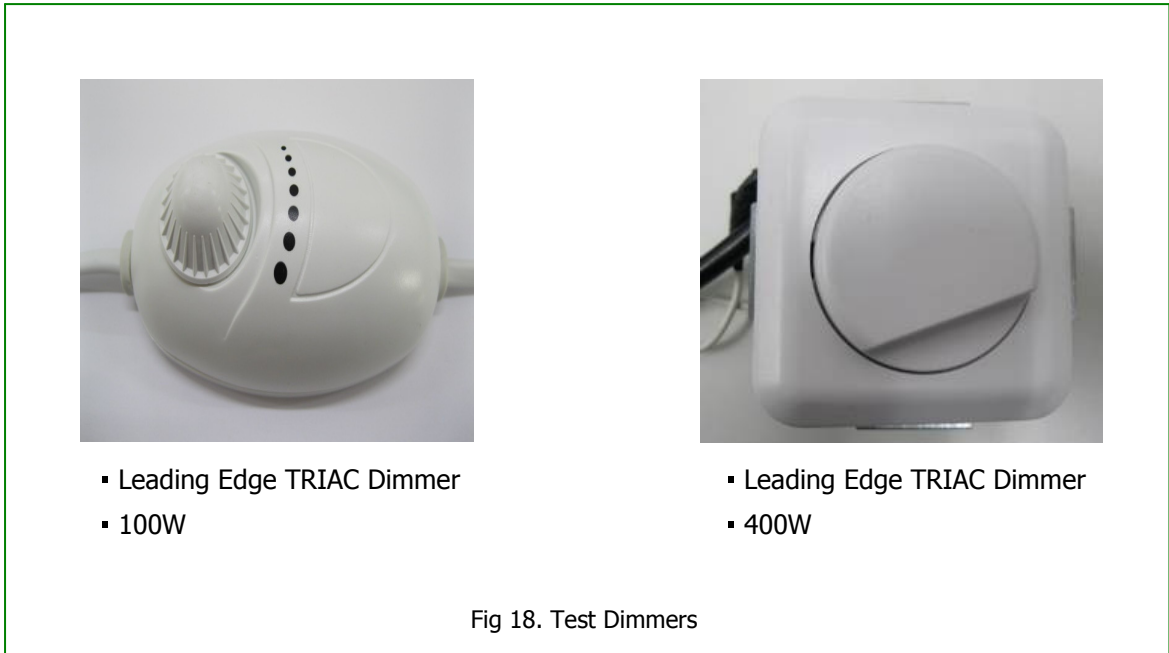

Table 6. Experimental Test Results of Acrich IC Module _ Dimming Range [1]

220V/60Hz	Type	Min. Dimming Range	Max. Dimming Range
100W TRIAC Dimmer	8W module	3.7 %	95.5 %
	12W module	2.2 %	95.0 %
	40W Incandescent	0.3 %	94.9 %
400W TRIAC Dimmer	8W module	8.2 %	78.6 %
	12W module	5.5 %	77.6 %
	40W Incandescent	1.3 %	74.7 %

[1] Dimming Range

- Min. Dimming Range (Travel Min) : Min. Light Output (With Dimmer) / Light Output (W/O Dimmer)
- Max. Dimming Range (Travel Max) : Max. Light Output (With Dimmer) / Light Output (W/O Dimmer)

2. Acrich IC Module Circuit Configurations

2.6 Dimming Performance of Acrich IC Module

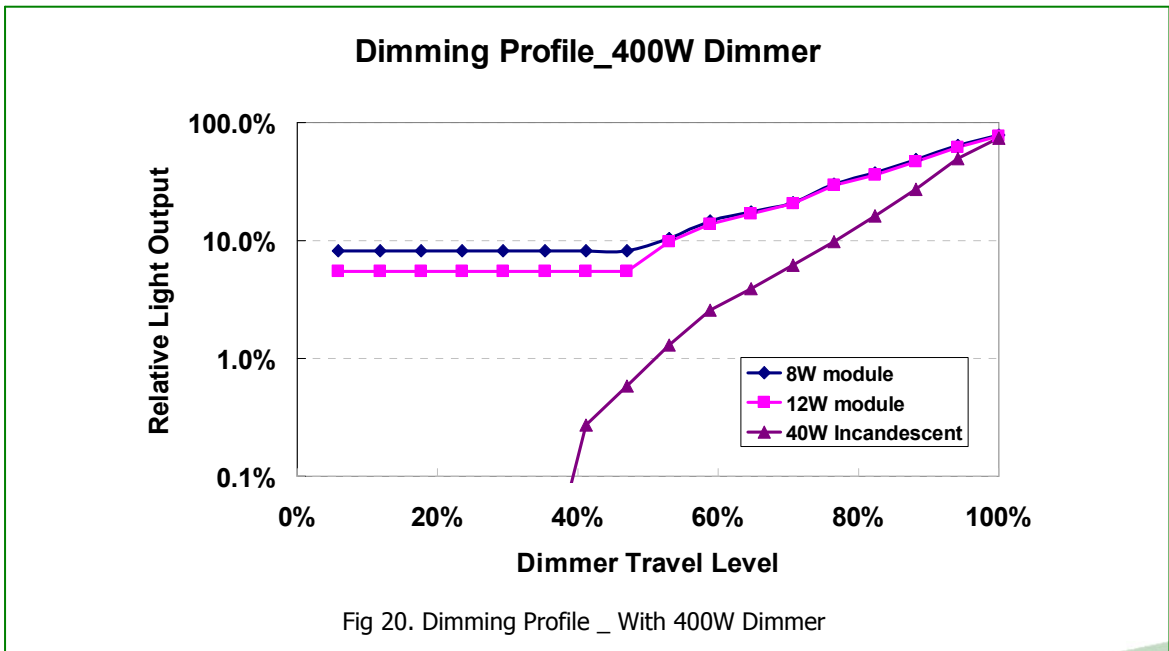
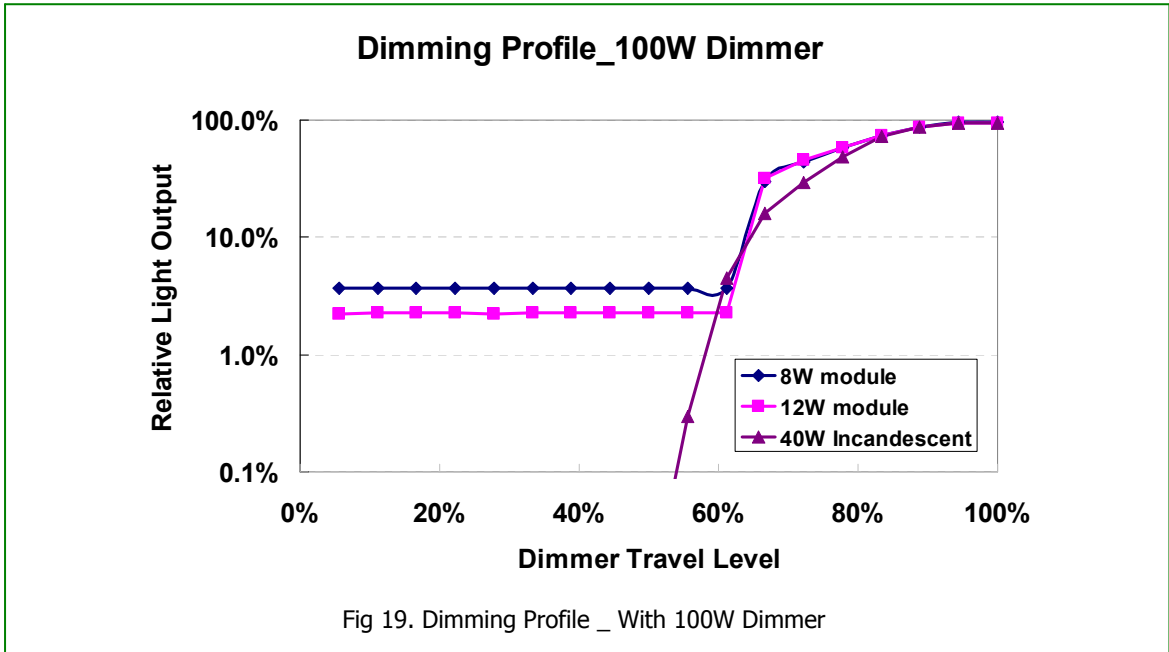

3. Electrical protection point

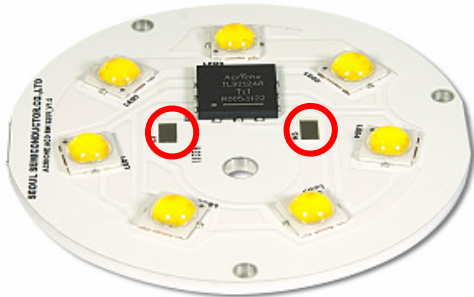

3.1 Wire solder pad protection

The red circles above are soldering pads for wires which directly connect with AC power. Do not touch wires by hands during working because of electrical shock. Thus, to avoid electrical shock, coating with resin which is strong against thermal shock such as silicon is necessary after soldering. Hardened Silicon at room temperature is not necessarily required curing but takes long time to dry. You can also use tape to cover the soldering instead of silicon coating.

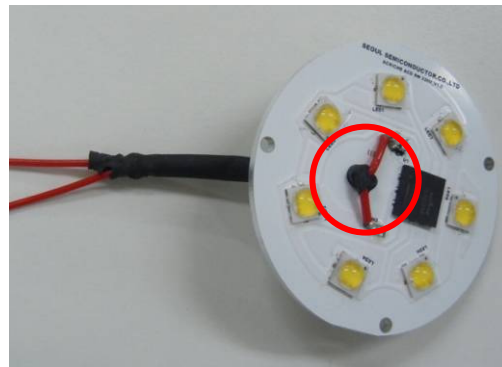

3.2 Wire hole in MCPCB Protection

- The red circle above is for AC power connecting wires. While wires go through the hole, they might be damaged. Therefore it is recommended to fill in the hole with same resin as wire. Furthermore, cylindrical protection can be used and insulation tape rapping can be used to protect wire.